



[pro]master®

100SL [*Speedlight*]

TTL Speedlight for Canon



Contents

Precautions	2
Foreword	3
Parts Identification	5
Basic Operation	7
LCD Panel	10
Custom Settings	15
Flash Modes	
E-TTL II Mode	16
Flash Exposure Bracketing	17
Flash Value Lock(FEL)	18
Front-Curtain/Rear-Curtain Sync	19
M(Manual) Mode	20
Repeat Mode	21
Wireless Flash Modes	
Master Mode	23
Slave Mode	32
F1/F2 Mode	34
Advanced Applications	
Adjusting The Flash Coverage	35
Bounce Flash Operation	36
Using the LED Light	37
Remote Camera Triggering	37
High-speed Sync / Key Lock	39
Advanced Wireless Flash	40
Troubleshooting Guide	41
Specifications	43
Appendix	44

Precautions

1. Do not disassemble, open, or repair this speedlight by yourself.
2. Always use batteries of the same type, brand, and age. Always replace all 4 batteries at the same time. Do not combine different types, brands, old, or new batteries. This could cause the batteries to overheat, leak, or explode.
3. This product is not water-resistant. Keep it away from rain, snow, and high humidity areas.
4. Install the batteries in proper orientation as indicated in the battery chamber. Installing the batteries incorrectly could cause them to overheat, leak, or explode.
5. If you change the batteries after a period of sustained continuous firing of the speedlight, the batteries may become warm or hot. This is normal, however you should be careful when handling these batteries.
6. Always switch the speedlight off before changing batteries.
7. Do not fire the speedlight from a short distance directly into the eyes of people or animals. This can cause damage to the retina and may even lead to blindness.
8. Avoid corrosive or flammable substances when cleaning this speedlight.
9. To prevent overheating and damage to the flash head, do not fire more than 25 continuous flashes in rapid sequence at full power (1/1 level). In this case the overheating mode will be activated and the flash will shut down. Allow it to return to normal operating temperature before using. This takes about 15 minutes.
10. Do not touch the speedlight with wet hands. This could cause an electrical shock.
11. Remove batteries from the unit before storing.

Foreword

Thank you for purchasing the [pro]master 100SL.

The ProMaster 100SL Speedlight is a high performance EOS compatible flash unit with a guide number of 100 ft (ISO 100 at the 50mm zoom position). The 100SL can easily perform various types of flash operations, such as manual and E-TTL II auto flash. It can server as an on-camera flash as well as a master unit or a slave unit in a wireless, multiple-speedlight system. It is also equipped with an LED light for videography and a wireless camera trigger for remote firing.

Here are some of the 100SL's features:

■ E-TTL II Mode

In this Canon wireless system, monitor pre-flashes are fired at all times, the subject is correctly exposed, and the overall exposure is less affected by challenging ambient light conditions.

■ Manual Mode

By setting the aperture and the flash output level, you can manually control the exposure.

■ RPT Mode

The 100SL fires repeatedly to create stroboscopic multiple-exposure effects in RPT mode. This operation is useful when shooting fast-moving subjects.

■ Advanced Wireless Lighting

In this mode, you can set slave units into three groups and control the mode and output level compensation values separately for each group.

■ Flash Exposure Lock

Flash Exposure Lock, or "FEL" controls the amount of flash exposure for a subject. Using FEL Lock with compatible cameras, you can lock in the appropriate flash exposure for the main subject. This flash exposure is locked in, even if you change the aperture or composition, or zoom the lens in and out.

■ Auto FP High-Speed Sync

High-Speed flash synchronization at the compatible camera's highest shutter speed is possible. This is useful when you want to use a wider aperture to achieve shallow depth of field to blur the background or create a "stop-motion" effect in your photograph.

■ Output level compensation / Exposure compensation

Flash output level compensation is performed by modifying the flash output level for the flash illuminated subject only. Exposure compensation is performed by intentionally modifying the correct exposure to modify both the subject and background exposure.

■ Rear-Curtain sync

Rear-Curtain flash sync creates a picture in which the blur of a moving subject appears behind the subject and not in front. In this mode, the speedlight fires just before the camera's rear shutter curtain starts to close.

■ Bounce flash

By tilting or rotating the flash head, you can bounce the light off a ceiling or wall to make use of reflected light.

■ Key lock

The speedlight's control buttons can be locked to prevent them from being pressed accidentally.

■ LCD panel backlight

This function sets the LCD panel backlight to on or off.

■ Standby function

This function automatically puts the 100SL in standby mode to conserve battery power after a period of inactive use.

■ Thermal Cut-off protection

This function protects the 100SL from high operating temperatures. If the temperature of the unit rises to a certain level, the 100SL will switch to protective shutdown mode.

● Read this instruction manual while also referring to your camera's instruction manual.

Before using the Speedlight, read this instruction manual and your camera's instruction manual to familiarize yourself with the Speedlight's operations.

Parts Identification

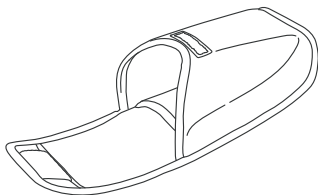
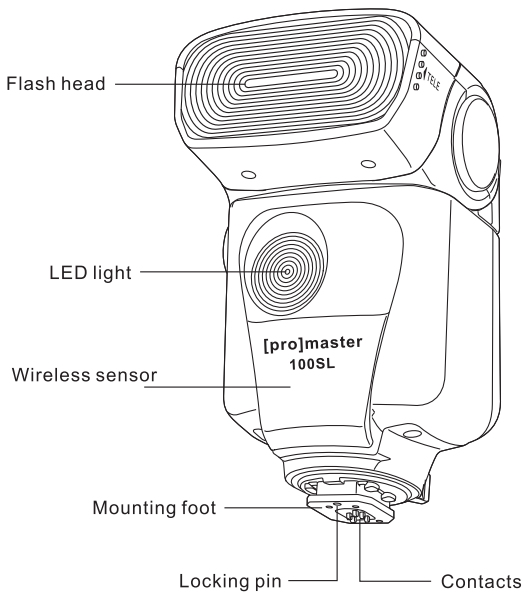

Soft Case

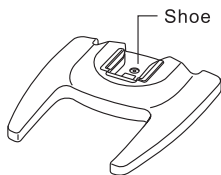

Mini stand

Parts Identification

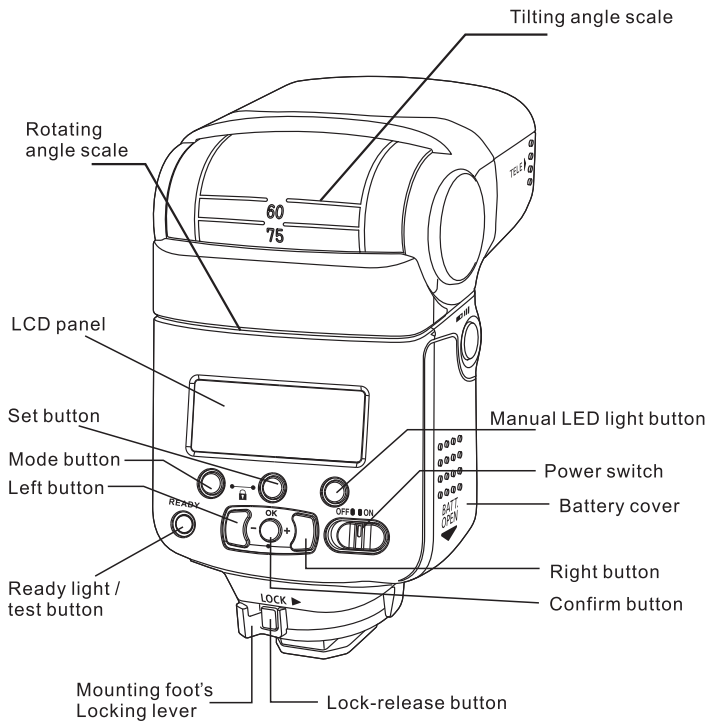

Basic Operation

Inserting The Batteries

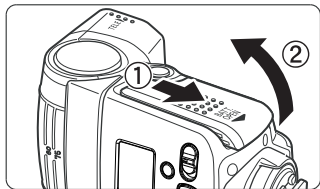

1 Open the cover.

Slide cover in direction of the arrow and flip open.

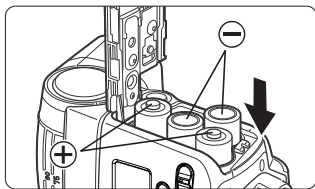

2 Install the batteries.

Make sure the + and - battery contacts are properly oriented as shown inside the battery compartment.

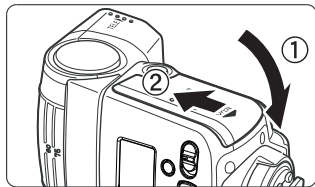

3 Close the cover.

Close the battery compartment cover by flipping it down, pressing, and sliding it closed.

- Only use size AA alkaline or Ni-Mh batteries.
- If you change the batteries after firing many continuous flashes be aware that the batteries might be hot.
- Before changing the batteries, be sure to turn off the speedlight.

Basic Operation

Attaching and Detaching the Speedlight

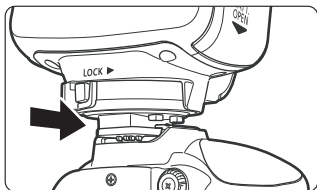

1 Attaching the speedlight.

Mount the speedlight into the camera's hot shoe all the way.

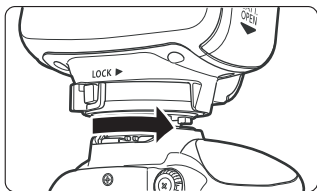

2 Securing the speedlight.

On the mounting foot, slide the lock lever to the right until it locks in place.

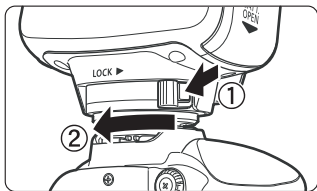

3 Detaching the speedlight.

While pressing the lock-release button, slide the lock lever to the left and detach the speedlight by sliding it out of the camera's shoe.

- Before attaching or detaching the speedlight, be sure to turn off the speedlight.

Basic Operation

Turning On the Power

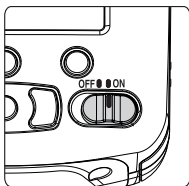

1 Turn on the power.

Slide the power switch to <ON>.



2 Check that the speedlight is ready.

The charging indicator is red while the speedlight is powering up. It will turn green and beep twice when the speedlight is ready to fire.

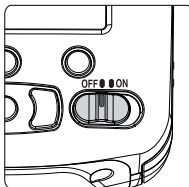

3 Turn off the power.

Slide the power switch to <OFF>.

- If the charging indicator remains red and the low power icon is displayed, replace the batteries with new ones.
- In order to conserve power, the speedlight will enter sleep mode after a specified time (this time can be adjusted in the Utility menu). The LCD will shut off. Press the camera's shutter button halfway or the <READY> button to wake it up.
- It will not enter sleep mode when in Remote or F1/F2 mode.





LCD Panel

LCD Panel

Icons in the LCD show the status of settings. Displayed icons vary according to selected flash modes and settings.

100SL status icons



	AF-assist illumination
	Thermal Cut-out on
	Sound on
	Communicating with a wireless compatible camera.

Low battery power indicator

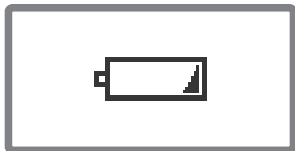

When battery power is low, this icon appears on the LCD and the 100SL stops working. Replace or recharge the batteries.

Temperature warning indicators



If the temperature of the unit becomes too high, this icon shown will appear in the LCD screen. You will hear short beeps for 15 seconds as the unit locks-up for thermal protection. Please turn off the speedlight for 15 minutes until it cools down. The 100SL will not resume normal operation until it is switched off and then back on after the waiting period.

Mode Icons



Press the <MODE> button to select a flash mode.



TTL	E-TTL II
M	Manual flash
RPT	Repeating flash

Examples of LCD Displays in TTL Mode



	High-speed sync
	Flash exposure compensation
	FEB Flash exposure bracketing
+0.3EV	Flash exposure compensation amount



Zoom position



24MM	Normal position
50MM	Extended position

Examples of LCD Displays in Manual Mode



	Front-Curtain Sync
	Rear-Curtain Sync
1/128+0.7EV	Flash output level at manual mode

Examples of LCD Displays in RPT Mode

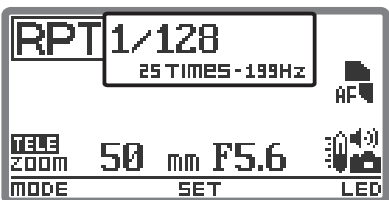

1/128	Flash output level
25 TIMES	Number of flashes
199Hz	Frequency

Examples of LCD Displays in Wireless Multiple Flash Shooting

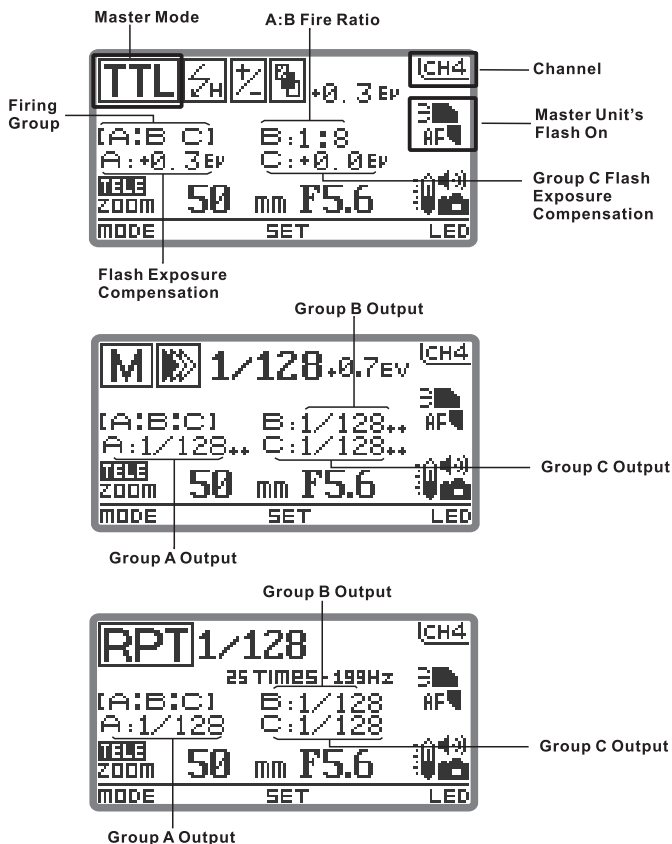

Remote Mode

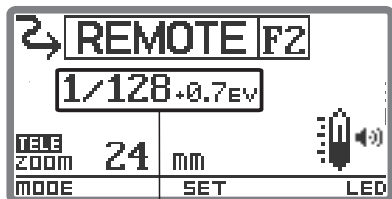
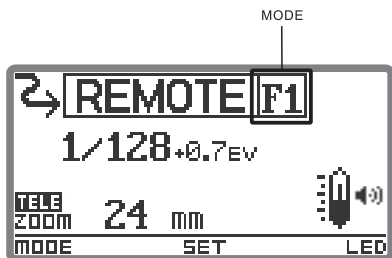
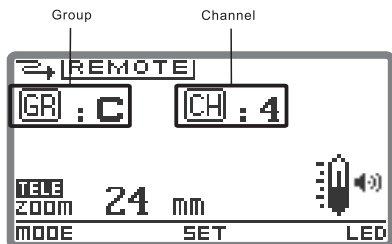

Flash output level at F2 mode

Custom Settings

You can customize the speedlight features to suit your shooting preferences with Custom settings.

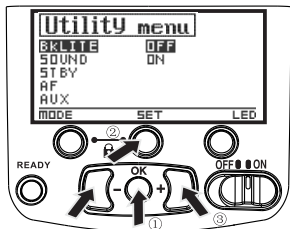

- 1 Press the <OK> button for approx. two seconds to display the Utility menu containing custom settings.
- 2 Press the <SET> button to highlight a setting. Press the <+> button to enter the highlighted setting. Continue pressing it to change that setting.
- 3 Press the <OK> button to save the setting and return to the custom settings.
- 4 When finished, press and hold the <OK> button for approx. two seconds to exit the Utility Menu.

BKLITE	Backlight
OFF ON	OFF:Turn off ON:Turn on
SOUND	Audible confirmation
OFF ON	OFF:Turn off ON:Turn on
ST BY	Standby function
NORMAL LONG SHORT OFF	NORMAL: 3Minutes LONG: 10Minutes SHORT: 1Minute OFF:Function canceled
The 100SL will not sleep in slave mode.	
AF	AF-assist illuminator
LED TUBE AUTO OFF	LED:Use LED TUBE:Use tube AUTO:Auto light OFF:Cancel AF-assist illumination
In AUTO mode the 100SL will switch from the LED to using short bursts of light from its flash tube in extremely dim light.	

AUX	LED fill light
OFF ON	OFF:Turn off ON:Turn on
AUX ON will turn the LED light on briefly each time you fire the flash to create a fill-light, especially useful when bouncing the main flash.	
FOCLEN	Focus display
PUL FOC	Show flash head position PUL: head position FOC: Show camera lens focal length
Adjust the flash head position, please refer to P25.	
TEMP	Thermal Cut-out
OFF ON	OFF:Turn off ON:Turn on
Warning: If you turn off the Thermal Cut-out, you can damage the 100SL by overheating the unit.	
RESET	Reset custom setting
RS	RS: Reset
VER	Version of firmware
12.6.15	Version

Flash Modes

E-TTL II Mode

In this mode information obtained by monitor pre-flashes and exposure control information are combined in-camera to automatically adjust flash output levels.

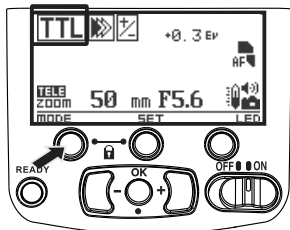

- 1 Press the <MODE> button and set the flash mode to TTL .**

- The default flash exposure compensation is 0.

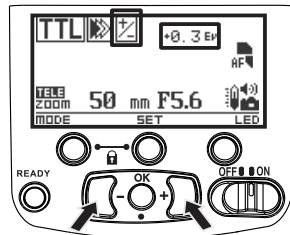

- 2 Set the flash exposure compensation.**

- Press the left/right buttons to decrease/increase the flash exposure compensation.
- The flash exposure compensation changes in 1/3 steps between -3.0 and +3.0.

Flash Modes

E-TTL II Mode

Flash Exposure Bracketing

Flash exposure bracketing can take three flash shots while automatically changing the flash output for each shot up to ± 3 stops in 1/3-stop increments (1/2-stop increments if the camera enables only 1/2-stop increments).



- 1 Press the <SET> button to highlight the FEB icon.

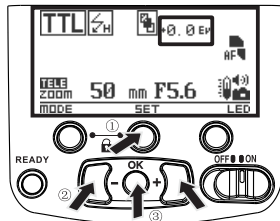

- 2 Tuning the FEB amount.
 - Press the left/right buttons to decrease / increase the amount.
 - Press the <OK> button to confirm.

- FEB mode will cancel itself after 3 shots. The speedlight will return to normal operation.
- Be sure the charging indicator light is green and the flash is ready before each shot.

Flash Modes

E-TTL II Mode

Flash Exposure Lock (FEL)

While in <TTL> mode you can use Flash Exposure Lock to lock-in the correct flash exposure for a specific part of the scene you are photographing.

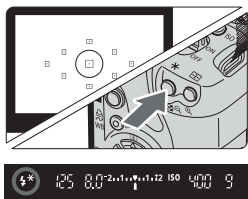

① Focus the subject.

② Press the <FEL> button on the camera.

- ① With the subject in the center of your viewfinder, press the camera's <FEL> or <*> button.
- ② The speedlight will fire a preflash to properly calculate exposure for the subject.
- ③ <*> will be displayed in the camera's viewfinder for 0.5s.
- ④ Each time you press the <FEL> button, a preflash will be fired and a new flash exposure setting will be locked.

- If the subject is too far away resulting in underexposure, the flash icon will blink in the camera's viewfinder. Move closer to the subject and try FEL again.

Flash Modes

E-TTL II Mode

Front-Curtain/Rear-Curtain Sync

In front-curtain sync, the speedlight fires immediately after the front shutter curtain opens completely; In rear-curtain sync, the speedlight fires just before the rear shutter curtain starts to close.

When shooting a fast-moving subject at slow shutter speeds, rear curtain sync. creates a more natural looking photograph with a blur shown behind the subject.

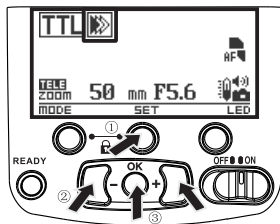

- 1 Press the <SET> button to highlight the <TTL> icon.



- 2 Select the Rear-Curtain Sync.

- Press the left/right buttons to switch between front and rear curtain sync.
- Press the <OK> button to confirm.

- Since slow shutter speeds are commonly used with rear-curtain sync, a tripod is recommended for best results.
- With E-TTL II, the speedlight will fire two flashes, even at slow shutter speeds. The first flash is only the pre-flash to aid in proper exposure.

Flash Modes

M Mode

You can set the speedlight to manual mode and choose a power level between 1/1 and 1/128.

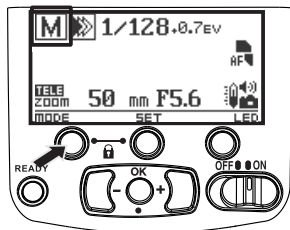

- 1 Press the <MODE> button and set the flash mode to M.

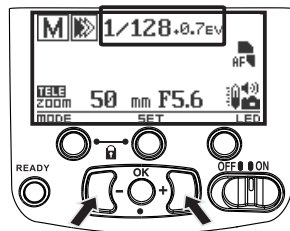

- 2 Set the flash output level.
 - Press the left/right buttons to decrease/increase the flash output level.
 - The flash output level changes in 1/3 steps between 1/128 and 1/1.

Flash Modes

Repeat Mode

In Repeat mode, the 100SL fires repeatedly during a single exposure, creating stroboscopic multiple-exposure effects. This operation is useful when shooting fast moving subjects.

You can set the firing frequency (number of flashes per second expressed as Hz), the number of flashes, and the flash output.

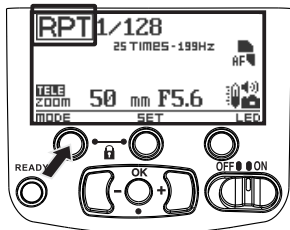

- 1 Press the <MODE> button and set the flash mode to RPT.

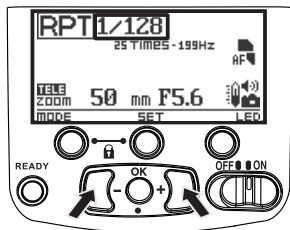

- 2 Set the flash output level.

- Press the left/right buttons to decrease /increase the flash output level.
- The flash output level changes between 1/128 and 1/4 power.

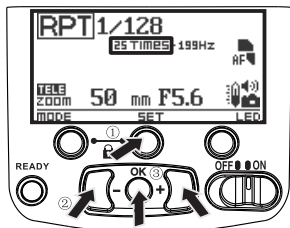

- 3 Set the number of flashes (times).

- ① Press the <SET> button to highlight the number.
- ② Press the left/right buttons to decrease/increase the number.
- ③ Press the <OK> button to confirm.

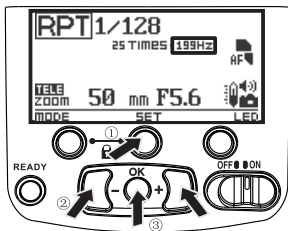

4 Set the firing frequency.

- Press the <SET> button to highlight the frequency.
- Press the left/right buttons to decrease/increase the number.
- Press the <OK> button to confirm.

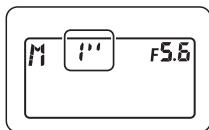

5 Set the shutter speed.

- Use the following equation to determine the shutter speed. Then set your camera to a shutter speed slower than the calculated number.

$$\text{Shutter speed} = \text{Number of flashes per frame} / \text{Frequency of flash (Hz)}$$
- For example, if the number of flashes per frame is 10 and the frequency is 5Hz, divide 10 by 5 to get a shutter speed of 2 seconds or slower (set a shutter speed of slower than 2 seconds)

- Using a tripod, remote switch, and external power source is recommended.
- To avoid overheating and deteriorating the flash head, don't use stroboscopic flash more than 10 times in succession. After 10 times, allow the speedlight to rest for at least 15 minutes.
- The maximum flash firing number is a function of output level and frequency. See the appendix for more details.

Wireless Modes

Master Mode

The 100SL can be used as a master unit in a wireless flash system. The settings you enter into the master unit (attached to the camera) are automatically transmitted to the slave units which are controlled by the master unit via wireless. You need not operate the slave unit(s) at all during the shoot. Wireless flash can be used in TTL, M, and RPT modes.

Wireless TTL flash



- 1 Set the speedlight to <E-TTL II> mode.

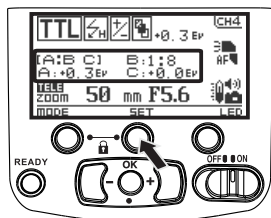

- 2 Set it as the master unit.

Press the <SET> button for 2 seconds or longer until the group and channel icons appear.

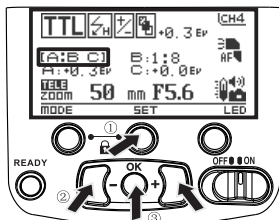

- 3 Firing Group.

- 1 Press the <SET> button to highlight group.
- 2 Press left/right buttons to select a firing group.
- 3 Press the <OK> button to confirm.

The following three firing groups are available:
<ABC>, <A:B>, <A:B C>.

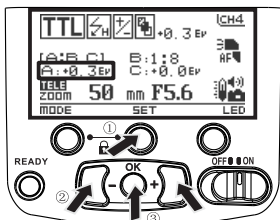

4 Set wireless flash exposure compensation.

- ① Press the <SET> button to highlight group A.
- ② Press the left/right buttons to select an EV (exposure value).
- ③ Press the <OK> button to confirm.

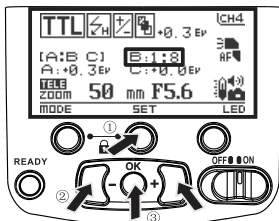

5 Set the flash ratio.

- ① Press the <SET> button to highlight group B.
- ② Press the left/right buttons to select the ratio.
- ③ Press the <OK> button to confirm.

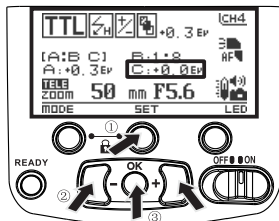

6 Set the flash exposure compensation of group C.

- ① Press the <SET> button to highlight group C.
- ② Press the left/right buttons to change the EV.
- ③ Press the <OK> button to confirm.

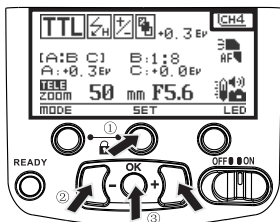

7 Set the Channel.

- ① Press the <SET> button to highlight channel.
- ② Press left/right buttons to change the channel number from 1 to 4.
- ③ Press the <OK> button to confirm.

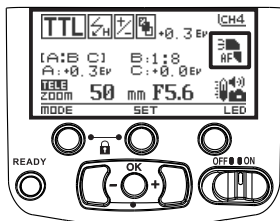

8 Master unit's flash ON/OFF.

- You can use the camera's menu to turn the master unit's flash on or off.
- Even if you disable the master unit's flash, it will still fire a pre-flash to transmit wireless signals.

- If another photographer is using the same type of wireless slave flash setup nearby, your slave flash units may accidentally fire in sync with that photographer's master flash unit. To avoid this use a different channel number.

Wireless Modes

Wireless Manual flash

With wireless manual flash, you can set a different flash output for each slave unit.

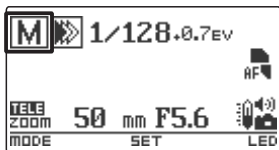

- 1 Set the speedlight to <M> mode.

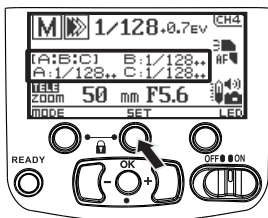

- 2 Set it as the master unit.

Press <SET> button for 2 sec. or longer until group and channel icons appear.

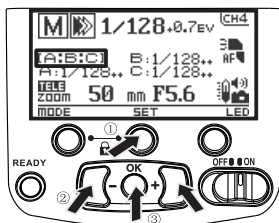

- 3 Firing Group.

- 1 Press the <SET> button to highlight group.
- 2 Press left/right buttons to select a firing group.
- 3 Press the <OK> button to confirm.

● The following three firing groups are available:
<ABC>, <A:B>, <A:B:C>.

Wireless Modes

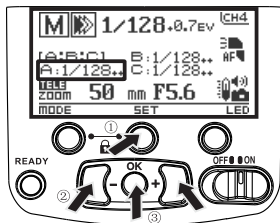

4 Change the flash power.

- 1 Press the <SET> button to highlight a group.
- 2 Press left/right buttons to change the power of that group.
- 3 Press the <OK> button to confirm.

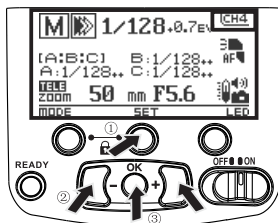

5 Set the Channel.

- 1 Press the <SET> button to highlight channel.
- 2 Press the left/right buttons to change the channel number.
- 3 Press the <OK> button to confirm.

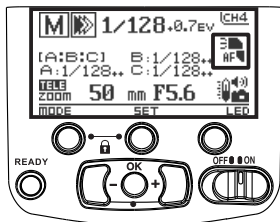

6 Master unit's flash ON/OFF.

- You can use camera's menu to turn the master unit's flash on or off.
- Even if you disable the master unit's flash it will still fire a pre-flash to transmit wireless signals.

- When the 100SL is set to the <ABC> firing group, you can set the flash output power for all groups at once.

Wireless Modes

Wireless RPT flash

With wireless RPT flash, you can set a different flash output for each slave unit. In this mode, all settings of flash frequency and the number of repeating flasher per frame will be the same among the master unit and slave units.

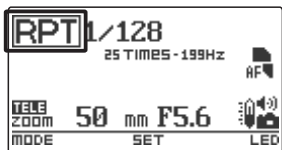

- 1 Set the speedlight to <RPT> mode.

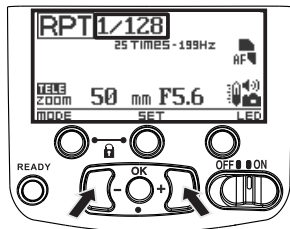

- 2 Set the flash output level.

- Press the left/right buttons to change the output level from 1/128 to 1/4.

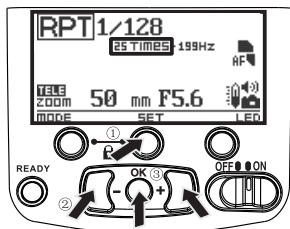

- 3 Set the number of flashes (times).

- ① Press the <SET> button to highlight the number.
- ② Press the left/right buttons to decrease/increase the number.
- ③ Press the <OK> button to confirm.

Wireless Modes

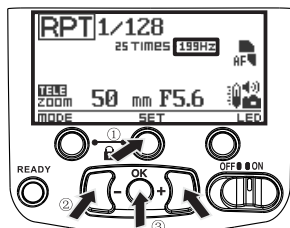

4 Set the firing frequency.

- Press the <SET> button to highlight the frequency.
- Press the left/right buttons to decrease/increase the number.
- Press the <OK> button to confirm.

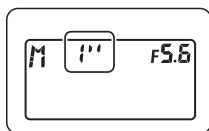

5 Set the shutter speed.

- Use the following equation to determine the shutter speed. Then set your camera to a shutter speed slower than the calculated number.
Shutter speed = Number of flashes per frame / Frequency of flash (Hz).
- For example, if the number of flashes per frame is 10 and the frequency is 5Hz, divide 10 by 5 to get a shutter speed of 2 seconds or slower (set a shutter speed of slower than 2 seconds).

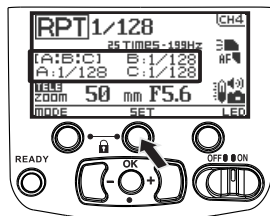

6 Set it as the master unit.

- Press the <SET> button for 2 seconds or longer until group and channel icons appear.

Wireless Modes

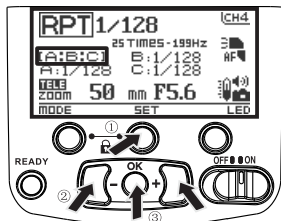

7 Firing Group.

- 1 Press the <SET> button to highlight group.
- 2 Press left/right buttons to select a firing group.
- 3 Press the <OK> button to confirm.

● The following three firing group modes are available:
<ABC>, <A:B>, <A:B:C>.

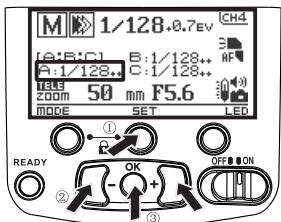

8 Set the output power for each group.

- 1 Press the <SET> button to highlight each group.
- 2 Press left/right buttons to change the number.
- 3 Press the <OK> button to confirm.

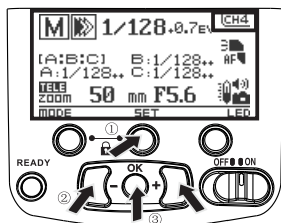

9 Set the Channel.

- 1 Press the <SET> button to highlight channel.
- 2 Press left/right buttons to change the channel number.
- 3 Press the <OK> button to confirm.

Wireless Modes

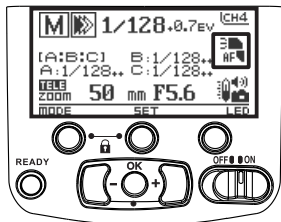

10 Master unit's flash ON/OFF.

- You can use camera's menu to turn the master unit's flash on or off.
- Even if you disable the master unit's flash, it will still fire a pre-flash to transmit wireless signals.

- To avoid overheating and deteriorating the flash head, don't use stroboscopic flash more than 10 times in succession. After 10 times, allow the speedlight to rest for at least 15 minutes.
- The maximum flash firing number is a function of output level and frequency. See the appendix for more details.

Wireless Modes

Slave(Remote) Mode

As a slave unit, the 100SL can receive signals from another 100SL, ProMaster 200SL, Canon 580EX II, ST-E2 and other Canon wireless flash system compatible items. In this mode, you can divide the slave units into three groups and set the flash mode and flash output level compensation values separately for each group as well as the master flash unit.

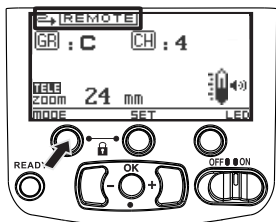

- 1 Press the <MODE> button for 2 seconds. to choose slave mode.

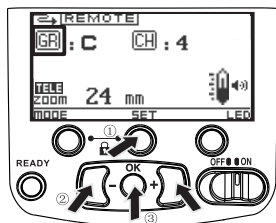

- 2 Set the Group

- 1 Press the <SET> button to highlight GR (group).
- 2 Press the left/right buttons to choose A, B, or C group.
- 3 Press the <OK> button to confirm.

- Select a group number from A/B/C.
- For slave flash units where the flash mode and flash output level compensation values are to be set identically, place these flash units into the same group.

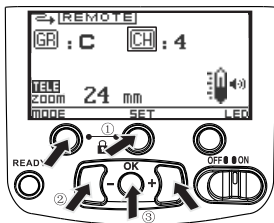

3 Set the Channel.

- ① Press the <SET> button to highlight Channel.
 - ② Press the left/right buttons to choose a channel between 1 and 4.
 - ③ Press the <OK> button to confirm.
- Be sure to choose the same channel number as set on the master flash unit.

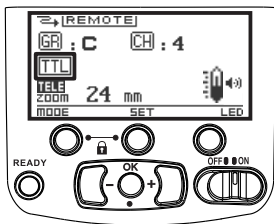

4 Parameter display.

- When the slave receives a TTL signal from the master, the <TTL> icon will appear in the LCD. This happens after the first remote firing of the slave flash.
- If the master is set to fire the slave in M or RPT, the slave will display the appropriate icon and settings after the first remote firing.

- When using the camera's built-in flash as a master unit remember to raise the built-in flash.

Wireless Modes

Slave Mode(F1/F2)

The F1 mode is used in a manual flash environment. The F2 mode is used in a TTL flash environment.

F1 mode

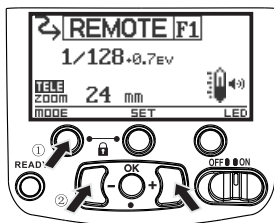

- ① First press the <MODE> button for 2 seconds to display the slave mode. Then press the <MODE> button to choose F1 mode.
- ② Set the flash output level.
 - Press the left/right buttons to decrease/increase the flash output level.
 - The flash output level changes in 1/3 steps between 1/128 and 1/1.

- When the speedlight is in F1 mode, it will fire in-sync. with the master flash, similar to a radio slave setup. To use this mode correctly, the master speedlight should be set as a manual flash and the TTL flash system with pre-flash and red-eye reduction modes should not be used.
- Press the left/right button to set the flash output level. (P20)

F2 mode

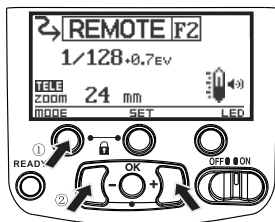

- ① First press the <MODE> button for 2 seconds to display the slave mode. Then press the <MODE> button to choose F2 mode.
- ② Set the flash output level.
 - Press the left/right buttons to decrease/increase the flash output level.
 - The flash output level changes in 1/3 steps between 1/128 and 1/1.

- When the speedlight is in F2 mode it can support the master speedlight in TTL mode.
- Press the left/right button to set the flash output level. (P20)

Advanced Applications

Adjusting The Flash Coverage

The flash head can be extended or retracted manually to match the lens focal length.

Flash head position

Normal position

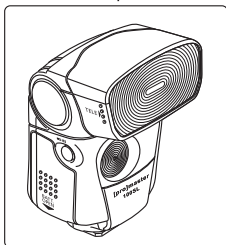

Guide number 23/75 (ISO 100 in M/ft)

Extended position

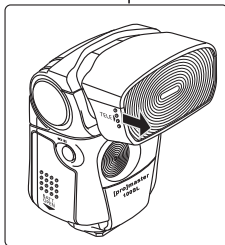

Guide number 30/100 (ISO 100 in M/ft)

Flash Head Position		Normal Position	Extended Position
Lens Focal Length	EF-S Lens	15mm or longer	32mm or longer
	EF Lens	24mm or longer	50mm or longer

- When using an EF-S lens with a focal length of 32mm or longer or an EF lens with a focal length of 50mm or longer, extend the flash head for greater flash output and longer flash range.
- Be sure the flash head is set properly to cover the focal length of your lens and avoid dark edges.

Advanced Applications

Bounce Flash Operation

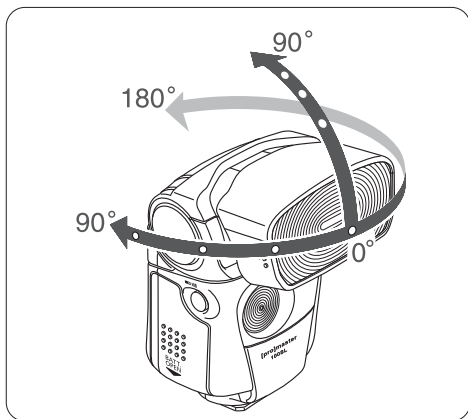

Tilt or rotate the 100SL's flash head to bounce the light off a ceiling or walls, providing more natural-looking pictures of people with softer shadows.

- If the wall or ceiling is too far away, the bounced flash might be too weak and can result in underexposure.
- Be sure to select a white/neutral surface to bounce the light off of. Otherwise your pictures will have an unnatural looking color cast similar to that of the reflecting surface.

Advanced Applications

Using the LED Light

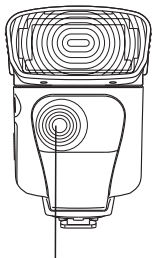

LED light

The LED light is ideal for shooting video.

- The LED light has an angle of view that will cover an EF lens of 50mm or longer or an EF-S lens of 32mm or longer.
- The LED light will last up to approximately 3.5 hours with new batteries.
- To activate the LED light simply press and hold the LED button for approximately 2 seconds until the light turns on. You may press the LED button again for 2 seconds to turn the LED light off.

- When using the LED light to shoot portraits, please keep the speedlight at least 1m away from the subject to avoid hurting their eyes.
- When the remaining battery power is low, the LED light may not turn on even if the flash-ready lamp is lit. If the LED light does not turn on replace the flash batteries.
- The LED light will not turn on when the 100SL is set to Slave Mode.

Using the 100SL for Remote Camera Triggering

The 100SL can be used to wirelessly trigger cameras which are compatible with the RC-1, RC-5, and RC-6 Canon remote controls. When using wireless flash this can be especially helpful by allowing you to fire the camera while aiming the flash.

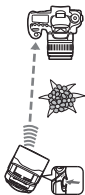

1 Set the camera to remote control shooting mode.

- Please refer to your camera's instruction manual.
- It is recommended that you shade the eyepiece of the camera viewfinder so that light does not enter while remote firing.

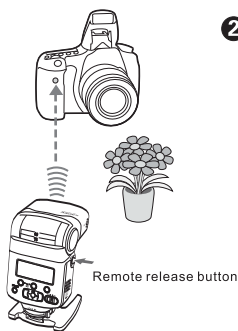

2 Taking the picture.

- Point the 100SL transmitter (front panel) toward the camera, and press the remote release button on the side of the 100SL (located near the battery compartment).
- The picture will be taken two seconds later. This delay allows you to redirect the flash towards your subject, if necessary.
- The 100SL will flash in-sync. with the camera if it is set to a wireless slave mode. Otherwise it will trigger the camera without flashing.

Bulb (Long Exposure) Shooting

When you press the remote release button during bulb shooting, the shutter opens two seconds later. Press the remote release button again to close the shutter.

- Be careful not to cover the remote control transmitter or wireless sensor of the 100SL with your hand.
- The remote control function has an operating range of about 5m/ 16.4 ft. from the front of the camera.
- Check the shooting results while performing remote control shooting.
- When the 100SL is not in <REMOTE> mode and you press the remote release button, a picture is taken two seconds later. However the 100SL will not flash in this case.

Advanced Applications

High-speed Sync (FP flash)

With high-speed sync (FP flash), the 100SL can synchronize with all camera shutter speeds. This is particularly helpful when you want to use aperture priority for fill-flash portraits.



Select < >.

- You can use the camera's menu or press the <SET> button on the 100SL. Use the left/right buttons to select the high-speed icon.

- With FP flash, the faster the shutter speed, the shorter the effective flash range will be.
- To return to normal flash firing, please select front/rear-curtain sync. or turn off high-speed sync. from the camera controls.
- RPT flash cannot be combined with FP flash.
- If you set a shutter speed that is the same or slower than the camera's normal flash sync speed, the HSS icon will not be displayed in the viewfinder.

Key Lock

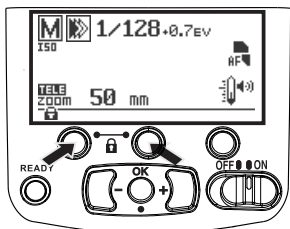

Pressing the MODE button and SET button simultaneously for 2 seconds locks the control buttons.

- The power ON-OFF switch will remain unlocked.
- A key icon is displayed on the LCD while the buttons are locked.

To cancel the key lock function, press the two buttons again for two seconds.

Advanced Applications

Advanced Wireless Flash

The 100SL supports multiple wireless flash setups.

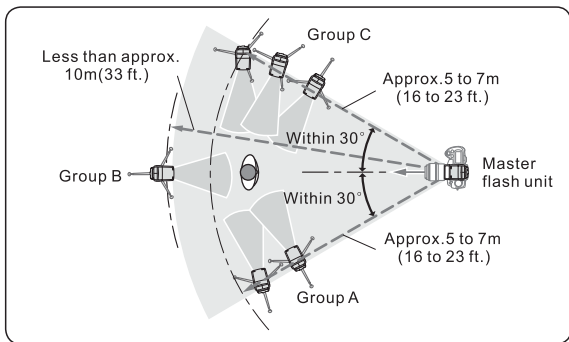

- The 100SL supports the Canon wireless flash system.
- The 100SL can be used as a master or slave flash.
- Be sure to test the wireless flash operation before shooting. When used as a slave unit, confirm each 100SL receives a good optical signal from the master.
- As a basic guide, the effective shooting distance between the master and slave units is approx. 10m (33 ft.) or less in the front position, and approx. 7m (23 ft.) at the sides. These ranges vary slightly depending on the ambient light.
- Indoors, the wireless signal can also bounce off a wall, so there is more leeway in positioning the slave units.
- Don't place any obstacles between the master unit and slave units. Obstacles can block the transmission of wireless signals.

Troubleshooting Guide

The Speedlight Does Not Fire

Possible cause: The batteries are installed in the wrong orientation.
Solution: Install the batteries in the correct orientation.

Possible cause: The batteries are exhausted.
Solution: Replace the batteries.

Possible cause: The speedlight is not attached securely to the camera.
Solution: Attach the speedlight's mounting foot securely to the camera.

Possible cause: The electrical contacts of the speedlight and/or camera are dirty.
Solution: Clean the contacts.

The Test Button (READY) Does Not Respond

Possible cause: The control buttons are locked.
Solution: Look at the LCD display. If the key icon appears, unlock the controls.

Possible cause: The LED light may be on.
Solution: Turn off the LED light. The flash cannot fire while the LED is on.

The Slave Unit Does Not Fire

Possible cause: The slave's mode is set wrong.

Solution: Set it to the same wireless mode, group, and channel as the master unit.

Possible cause: The slave unit is not positioned properly.

Solution: Place the slave unit with the master unit's transmission range.

Specifications

Type:	On-camera, E-TTL II speedlight
Guide No.:	GN 30 / 100' (at 50mm focal length, ISO 100)
Flash coverage:	24mm or 50mm <ul style="list-style-type: none">● Manual zoom
Wireless mode:	<ul style="list-style-type: none">● Canon wireless flash mode (master & slave modes)● F1/F2 mode
Audible:	Can be turned on or off
Display type:	LCD Dot Matrix Screen with LED Backlight
Protection type:	Thermal Cut-out (can be turned on or off)
Power supply:	4 x AA size batteries (Alkaline or Ni-Mh)
Duration range:	1/800~1/20000S
Recycle time:	approx 5s(AA alkaline cell use) approx 2s(AA Ni-Mh cell use)
Color temperature:	5600K
Flash control:	22 Levels light quantity output control (1/1 ~1/128, 14 levels of fine tuning); E-TTL II autoflash; Repeat flash
Power saving:	Customizable via the standby function
Vertical rotation angle:	-0° ~90°
Horizontal rotation angle:	Right 0°~90° / Left 0°~180°
Dimensions:	5 1/2" x 2 3/4" x 2" (140mm x 70mm x 50mm)
Net weight:	9 3/4oz / 275g (without batteries)

Appendix

Guide No. (at ISO 100, in meters)

Flash Output	1/1	1/2	1/4	1/8	1/16	1/32	1/64	1/128
24mm (flash head in normal position)	23	16	11.5	8	5.8	4	2.9	2
50mm (flash head in extended position)	30	21.2	15	10.6	7.5	5.3	3.8	2.7

Maximum number of repeating flash per frame

Referring to the table below, set the flash output level, the frequency, and the number of repeating flashes separately for each picture.

Frequency	Flash output level					
	M1/4	M1/8	M1/16	M1/32	M1/64	M1/128
1Hz	7	14	30	60	90	90
2Hz						
3Hz	7	14	30	60	90	90
4Hz	6	12	20	50	80	80
5Hz	5	10	20	40	70	70
6Hz	4	8	20	32	56	56
7Hz	3	6	20	28	44	44
8Hz	2	6	20	24	36	36
9Hz	2	5	10	22	32	32
10Hz	2	5	10	20	28	28
11Hz	2	4	8	12	25	25
199Hz						

One Year Unconditional Warranty

If for any reason, this ProMaster product fails within ONE YEAR of the date of purchase, return this product to your ProMaster dealer and it will be exchanged for you at no charge. ProMaster products are guaranteed for ONE FULL YEAR against defects in workmanship and materials. If at any time after one year, your ProMaster product fails under normal use, we invite you to return it to ProMaster for evaluation.

WWW.PROMASTER.COM | FAIRFIELD CT 06825

**FOR
CANON**

Made in China

Code 6354



0 29144 06354 2